

CABLE TRUNKING & ACCESSORIES

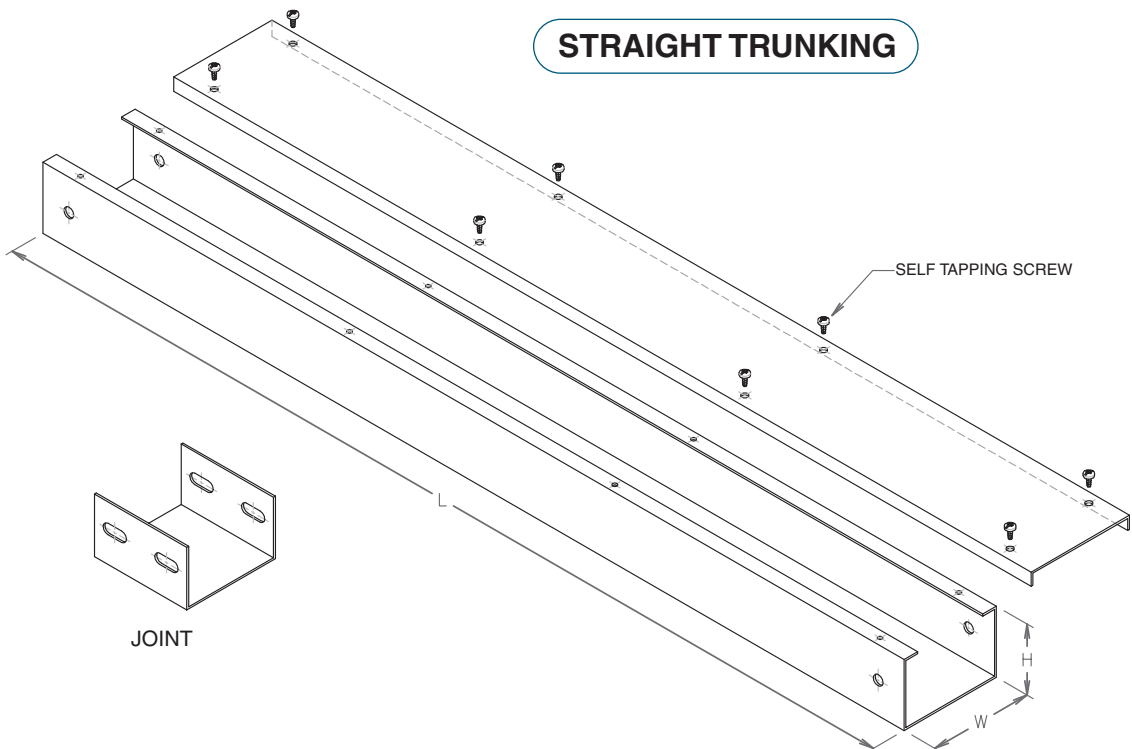

PRODUCT LIST			
HEIGHT (H)	WIDTH (W)	LENGTH (L)	THICKNESS (T)
25	50	2438	22G
50	50	2438	22G
50	75	2438	22G
50	100	2438	22G
50	150	2438	22G
75	75	2438	22G
75	100	2438	22G
25	50	2438	20G
50	50	2438	20G
50	75	2438	20G
50	100	2438	20G
50	150	2438	20G
75	75	2438	20G
75	100	2438	20G
75	150	2438	20G
100	100	2438	20G
100	150	2438	20G
25	50	2438	18G / 16G
50	50	2438	18G / 16G
50	75	2438	18G / 16G
50	100	2438	18G / 16G
50	50	2438	18G / 16G
75	75	2438	18G / 16G
75	100	2438	18G / 16G
75	150	2438	18G / 16G
100	100	2438	18G / 16G
100	150	2438	18G / 16G
100	200	2438	18G / 16G
100	250	2438	18G / 16G
100	300	2438	18G / 16G

COVER FASTENING METHOD

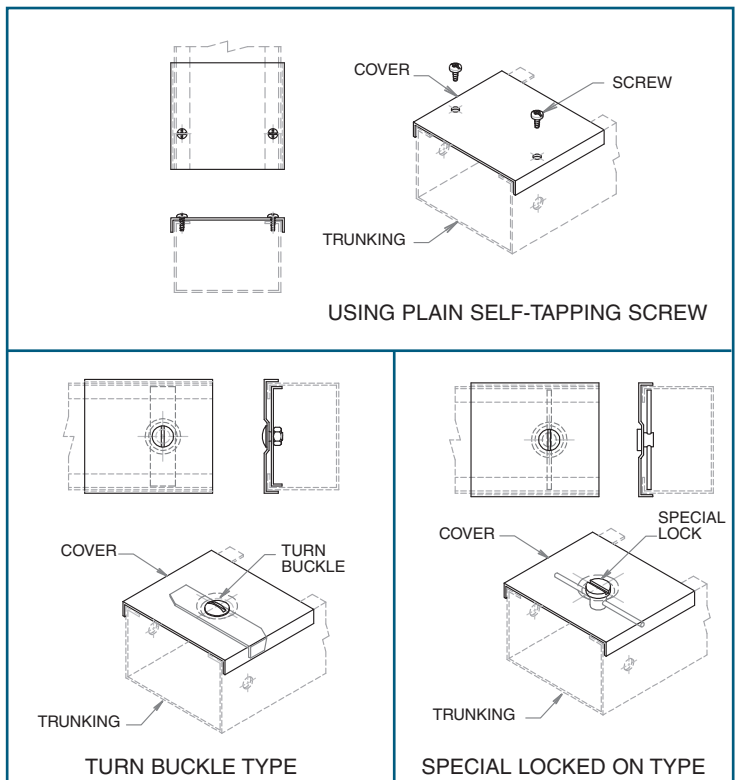

MATERIALS & FINISHING:

- 1 Pre-Galvanized steel to BS 2989 : 1982 & Original Finishing
- 2 Hot-Rolled Steel to BS1449 : Part 1 : 1983 & HDG to BS729:1971 or ASTM A386-73
- 3 Mild Steel to BS1449 : Part 1 : 1983 & Epoxy Coated
- 4 Hot-Rolled Steel to BS1449:Part 1 : 1983 & HDG to BS729:1971 or ASTM: A386-73 & Epoxy

NOTE: Other sizes are available upon request

•All units in (mm)

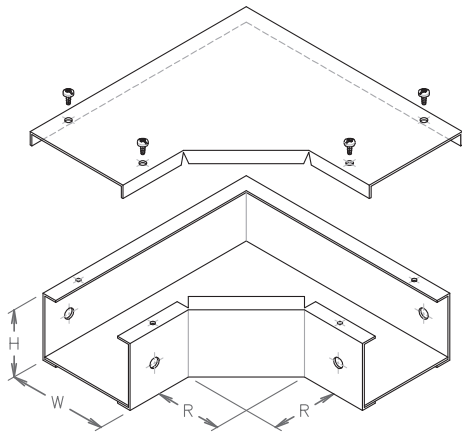

90 DEG. HORIZONTAL FLAT ELBOW

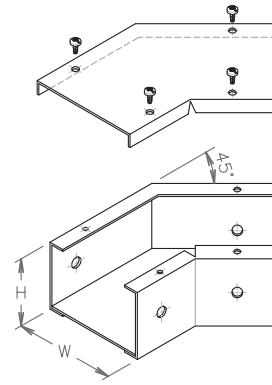

45 DEG. HORIZONTAL FLAT ELBOW

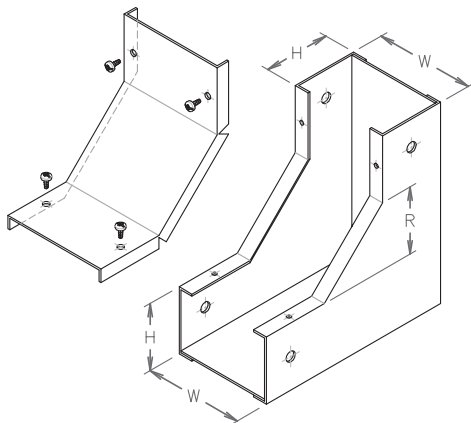

90 DEG. VERTICAL INSIDER RISER

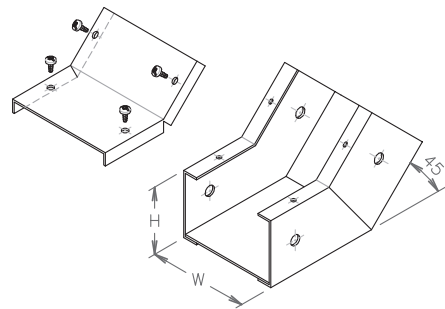

45 DEG. VERTICAL INSIDER RISER

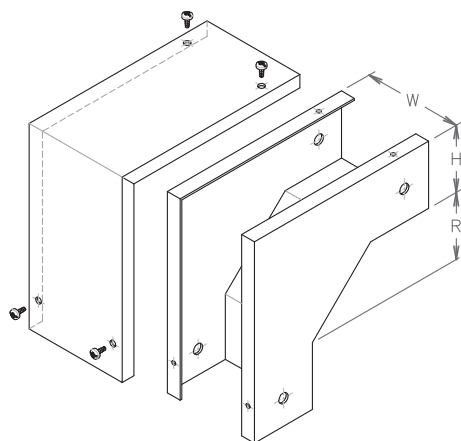

90 DEG. VERTICAL OUTSIDER RISER

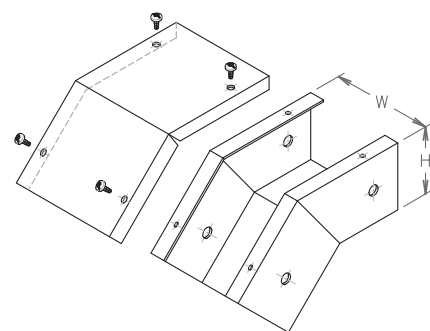

45 DEG. VERTICAL OUTSIDER RISER

CABLE TRUNKING & ACCESSORIES

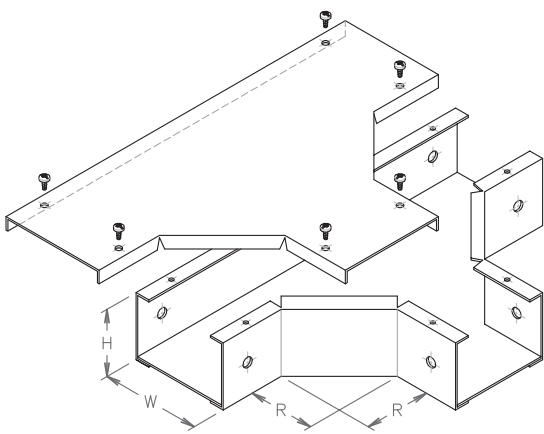

HORIZONTAL EQUAL TEE

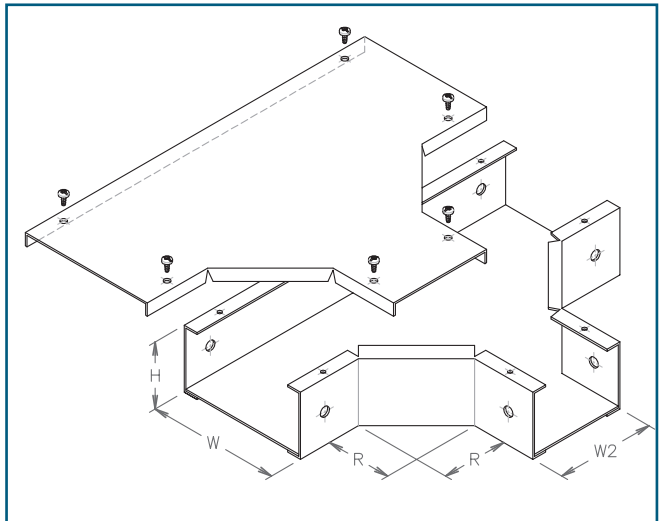

HORIZONTAL UNEQUAL TEE

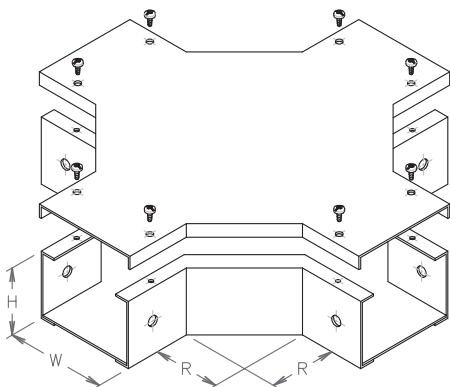

HORIZONTAL EQUAL CROSS

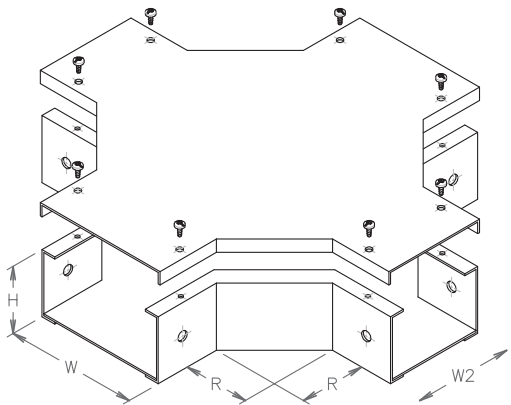

HORIZONTAL UNEQUAL CROSS

PRODUCT LIST

HEIGHT (H)	WIDTH (W)	RADIUS (R)	THICKNESS (T)
25	50	50	22G
50	50	50	22G
50	75	50	22G
50	100	50	22G
50	150	50	22G
75	75	50	22G
75	100	50	22G
25	50	50	20G
50	50	50	20G
50	75	50	20G
50	100	50	20G
50	150	50	20G
75	75	50	20G
75	100	50	20G
75	150	50	20G
100	100	50	20G
100	150	50	20G
25	50	50	18G / 16G
50	50	50	18G / 16G
50	75	50	18G / 16G
50	100	50	18G / 16G
50	150	50	18G / 16G
75	75	50	18G / 16G
75	100	50	18G / 16G
75	150	50	18G / 16G
100	100	50	18G / 16G
100	150	50	18G / 16G
100	200	50	18G / 16G
100	250	50	18G / 16G
100	300	50	18G / 16G

*All units in mm

NOTE: Other sizes are available upon request

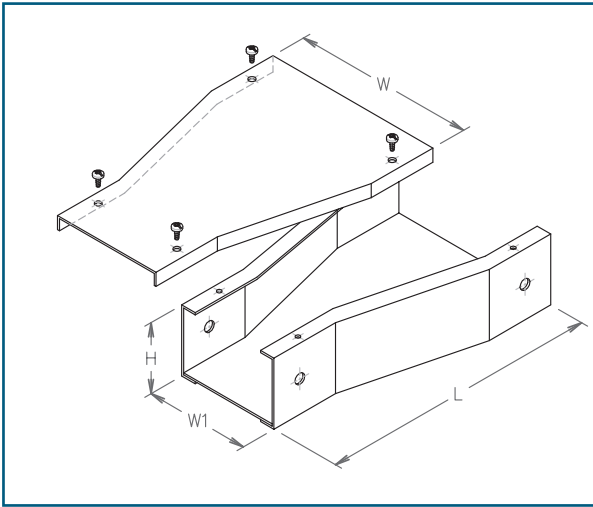

STRAIGHT REDUCER

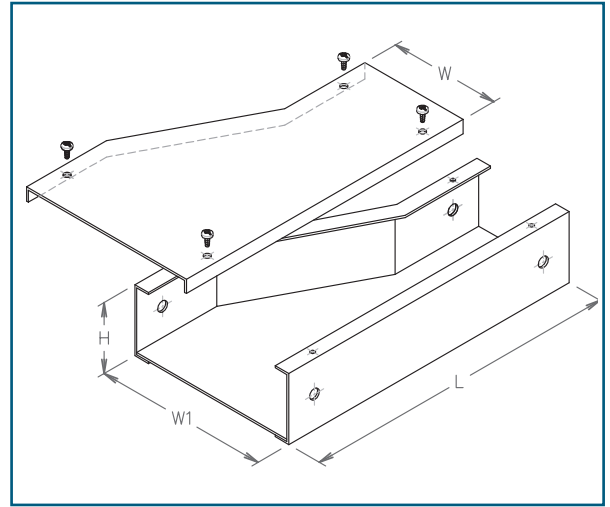

RIGHT-HAND REDUCER

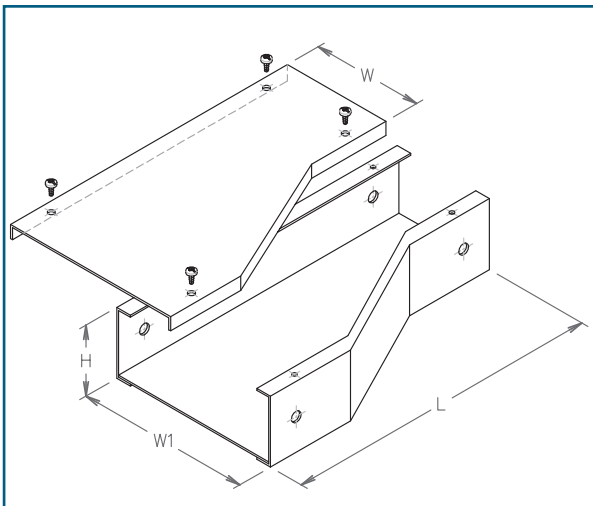

LEFT-HAND REDUCER

PRODUCT LIST				
WIDTH (W)	HEIGHT (H)	WIDTH (W1)	LENGTH (L)	THICKNESS (T)
150	25 / 50	50	300	0.8 / 1.5
200	50 / 75	50	300	0.8 / 0.5
200	50 / 100	75	300	1.0 / 1.5
250	50 / 100	75	300	1.0 / 1.5
250	100	100	300	1.0 / 1.5
300	100	100	300	1.0 / 1.5
300	100	150	300	1.0 / 1.5
450	100	200	300	1.5

*All units in mm

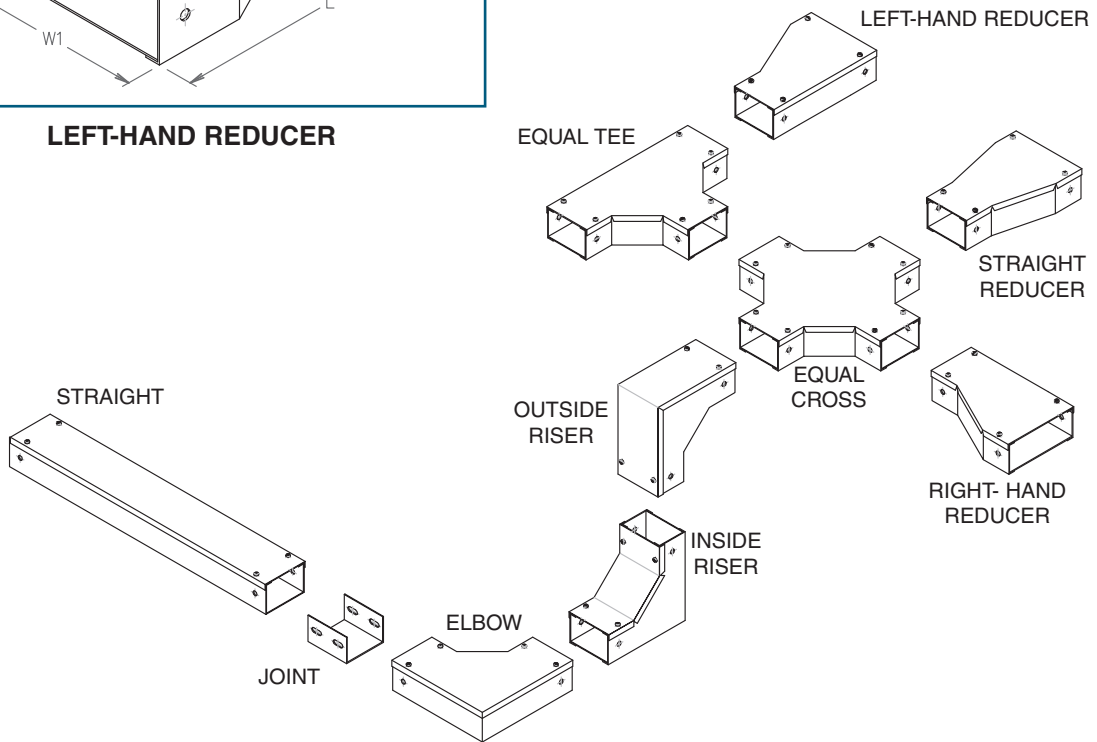

• A PREFABRICATED METAL STRUCTURE CONSISTING OF ONE PIECE BOX CHANNEL SECTION