

STRAIGHT DUCTING

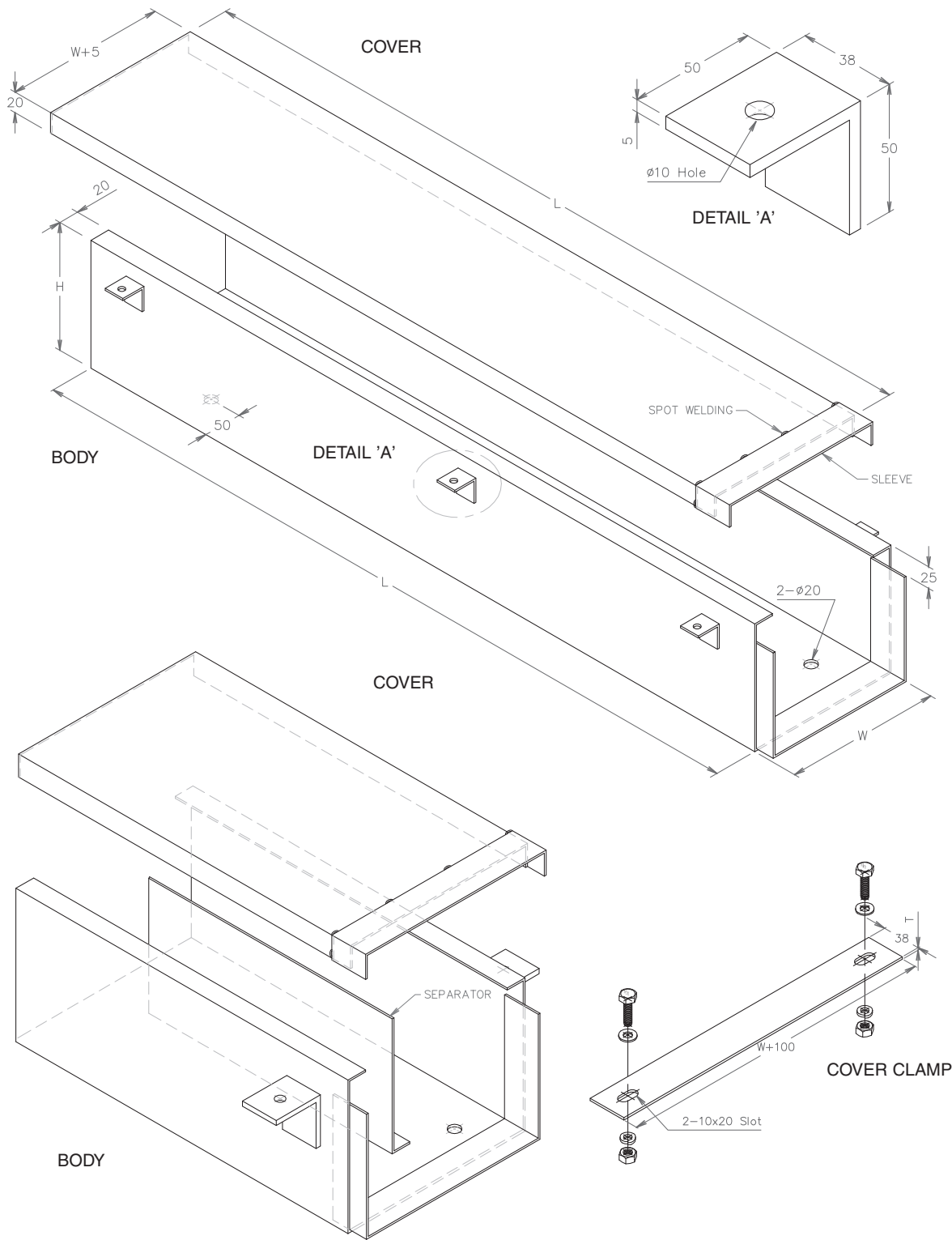

90 DEG. HORIZONTAL FLAT BEND

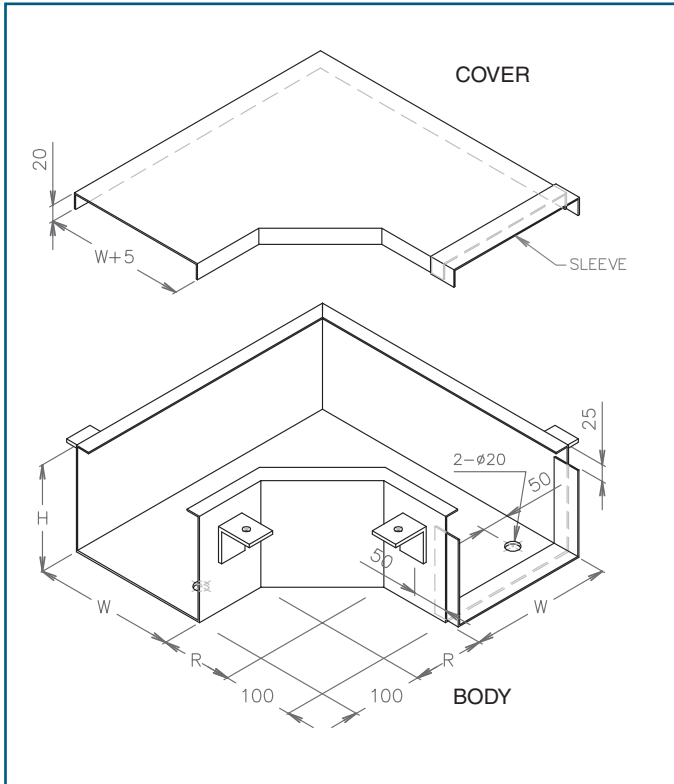

45 DEG. HORIZONTAL FLAT BEND

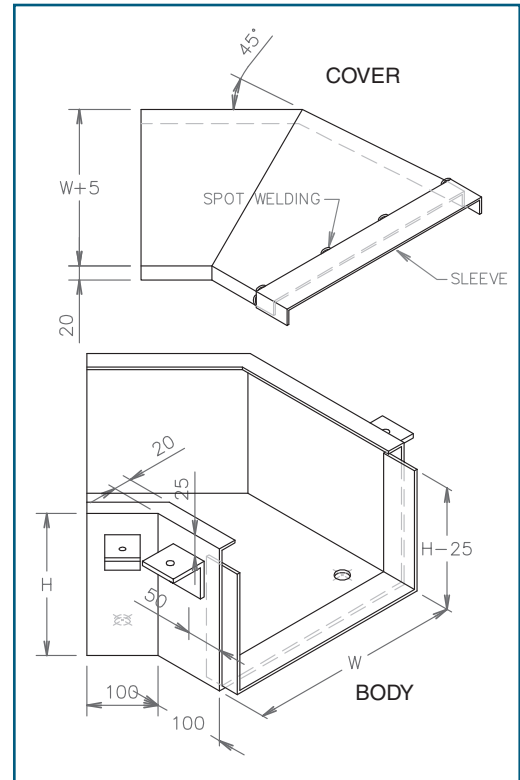

90 DEG. HORIZONTAL BEND C/W SEPARATOR

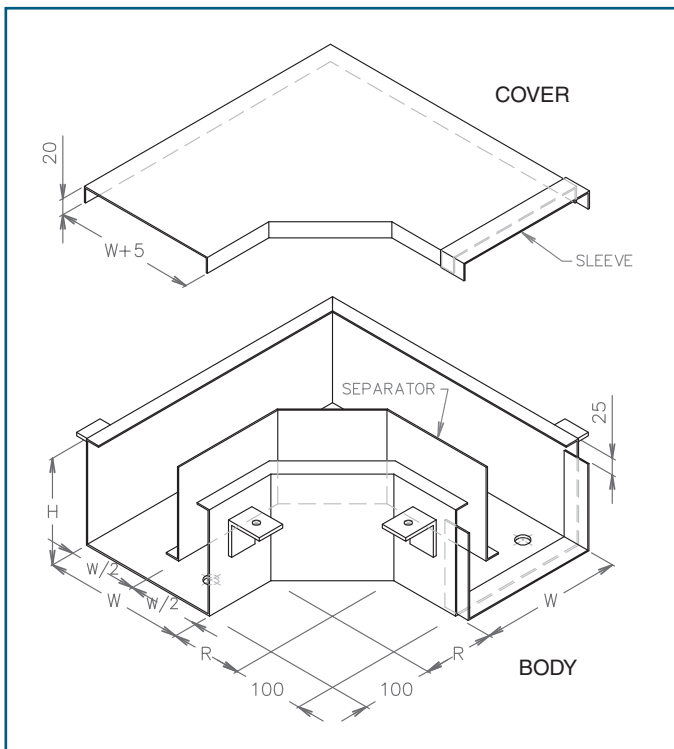

PRODUCT LIST

WIDTH (W)	HEIGHT (H)	LENGTH (L)	THICKNESS (T)
200	100	2440 / 3000	2.0
300	100	2440 / 3000	2.0
500	100	2440 / 3000	2.0
600	100	2440 / 3000	2.0
200	200	2440 / 3000	2.0
300	200	2440 / 3000	2.0
500	200	2440 / 3000	2.0
600	200	2440 / 3000	2.0
800	200	2440 / 3000	2.3 / 2.5
1000	200	1500	2.3 / 2.5 / 3.0
300	300	2440 / 3000	2.0
500	300	2440 / 3000	2.0
600	300	2440 / 3000	2.0
800	300	2440 / 3000	2.3 / 2.5
1000	300	1500	3.0
400	400	2440 / 3000	2.0
800	400	1500 / 3000	2.5
1200	400	1500 / 3000	3.0

*All units in mm

NOTE: Other sizes are available upon request

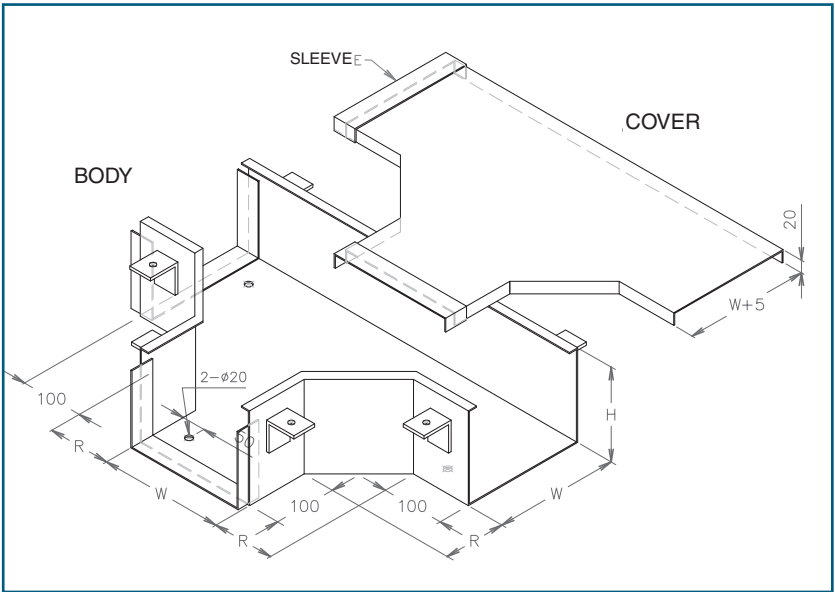

**HORIZONTAL EQUAL TEE
(W/O SEPARATOR)**

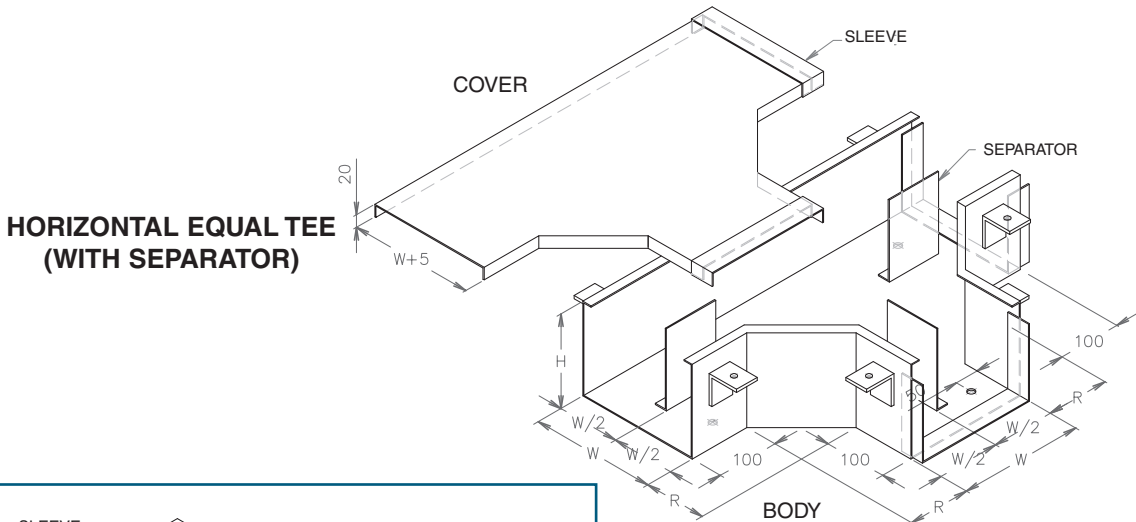

**HORIZONTAL EQUAL TEE
(WITH SEPARATOR)**

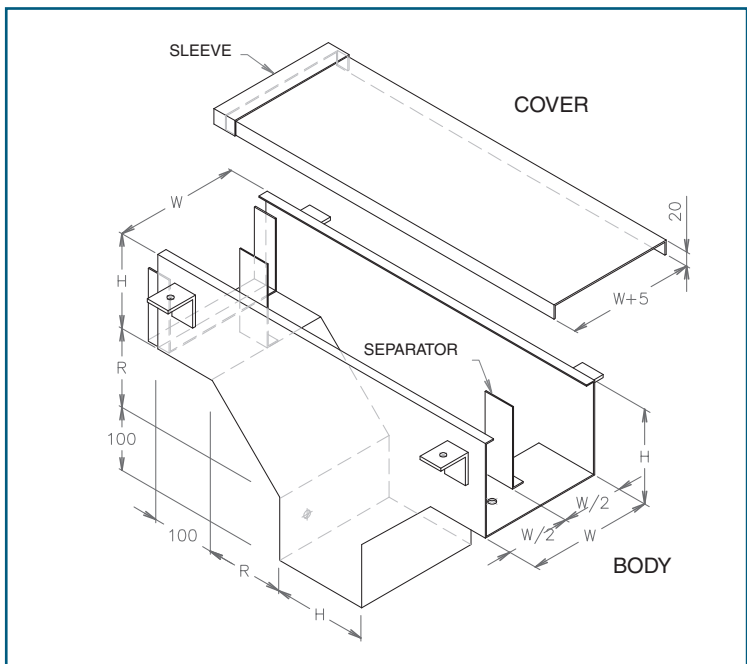

**VERTICAL TEE
(WITH SEPARATOR)**

90 DEG. VERTICAL INSIDE RISER (W/O SEPARATOR)

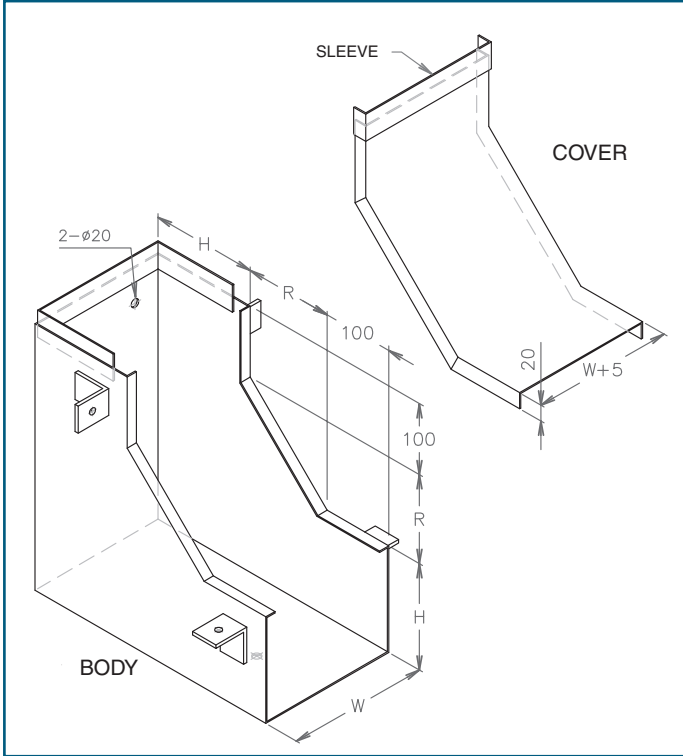

45 DEG. VERTICAL INSIDE RISER

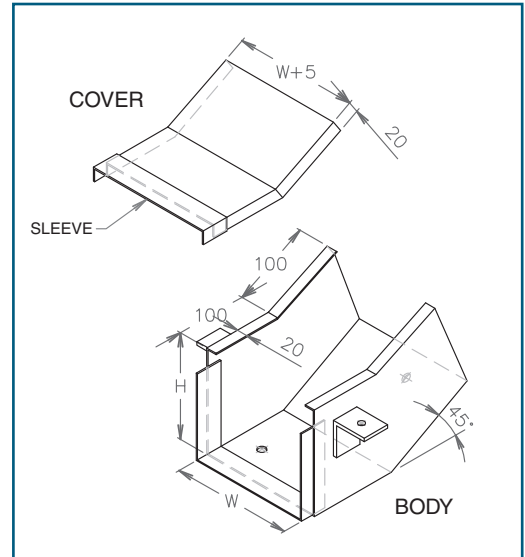

90 DEG. VERTICAL INSIDE RISER (WITH SEPARATOR)

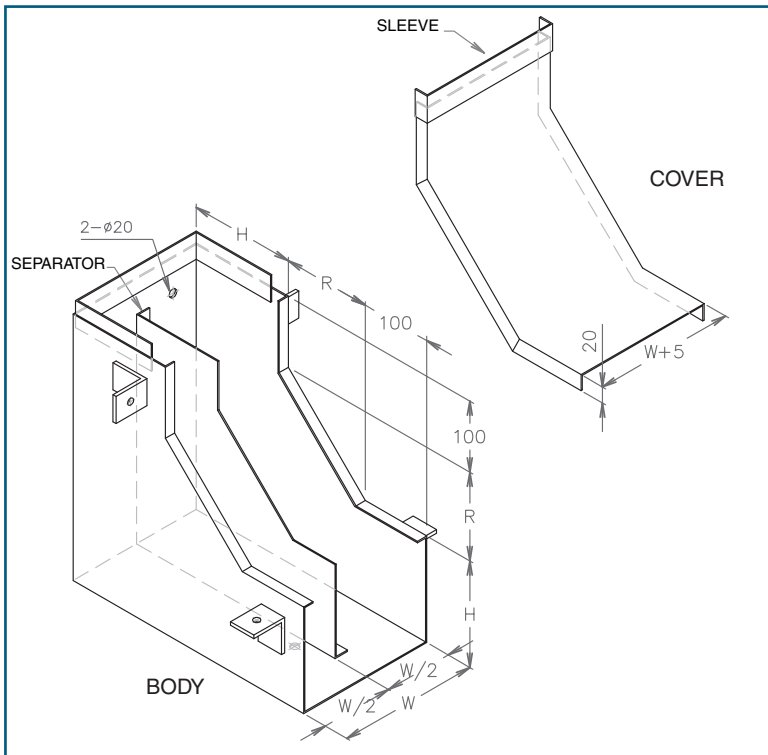

PRODUCT LIST

WIDTH (W)	HEIGHT (H)	RADIUS (R)	THICKNESS (T)
200	100	300 / 600	2.0
300	100	300 / 600	2.0
500	100	300 / 600	2.0
600	100	300 / 600	2.0
200	200	300 / 600	2.0
300	200	300 / 600	2.0
500	200	300 / 600	2.0
600	200	300 / 600	2.0
800	200	300 / 600	2.3 / 2.0
1000	200	300 / 600	2.3 / 2.5 / 3.0
300	300	300 / 600	2.0
500	300	300 / 600	2.0
600	300	300 / 600	2.0
800	300	300 / 600	2.3 / 2.5
1000	300	300 / 600	3.0
400	400	300 / 600	2.0
800	400	300 / 600	2.5 / 3.0
1200	400	300 / 600	2.5 / 3.0

*All units in mm

NOTE: Other sizes are available upon request

90 DEG. VERTICAL OUTSIDE RISER (W/O SEPARATOR)

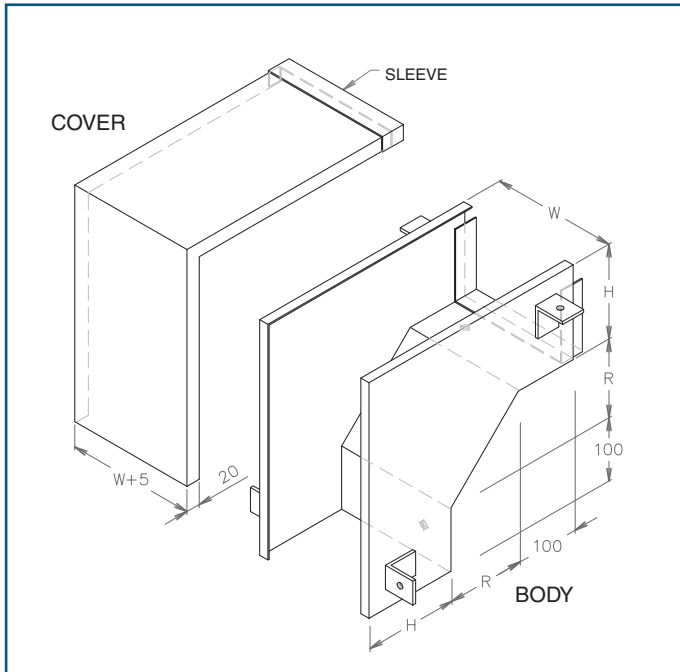

45 DEG. VERTICAL OUTSIDE RISER

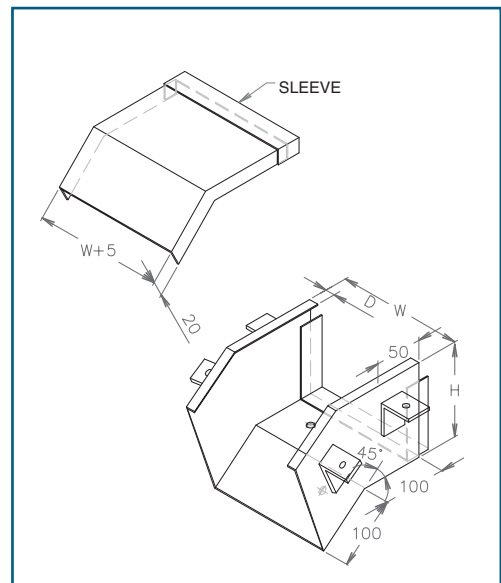

90 DEG. VERTICAL OUTSIDE RISER (WITH SEPARATOR)

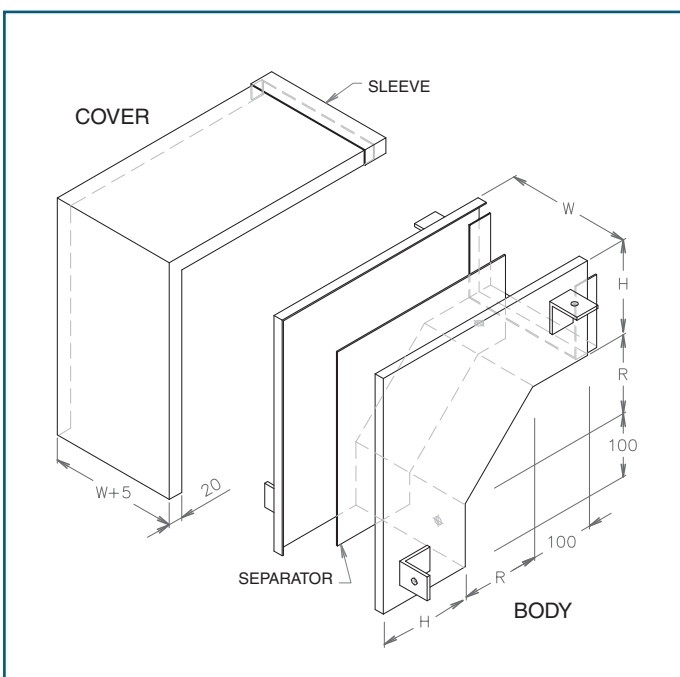

PRODUCT LIST

WIDTH (W)	HEIGHT (H)	RADIUS (R)	THICKNESS (T)
200	100	300 / 600	2.0
300	100	300 / 600	2.0
500	100	300 / 600	2.0
600	100	300 / 600	2.0
200	200	300 / 600	2.0
300	200	300 / 600	2.0
500	200	300 / 600	2.0
600	200	300 / 600	2.0
800	200	300 / 600	3.0
1000	200	300 / 600	3.0
300	300	300 / 600	2.0
500	300	300 / 600	2.0
600	300	300 / 600	2.0
800	300	300 / 600	3.0
1000	300	300 / 600	3.0
400	400	300 / 600	2.0
800	400	300 / 600	3.0
1200	400	300 / 600	3.0

*All units in mm

NOTE: Other sizes are available upon request

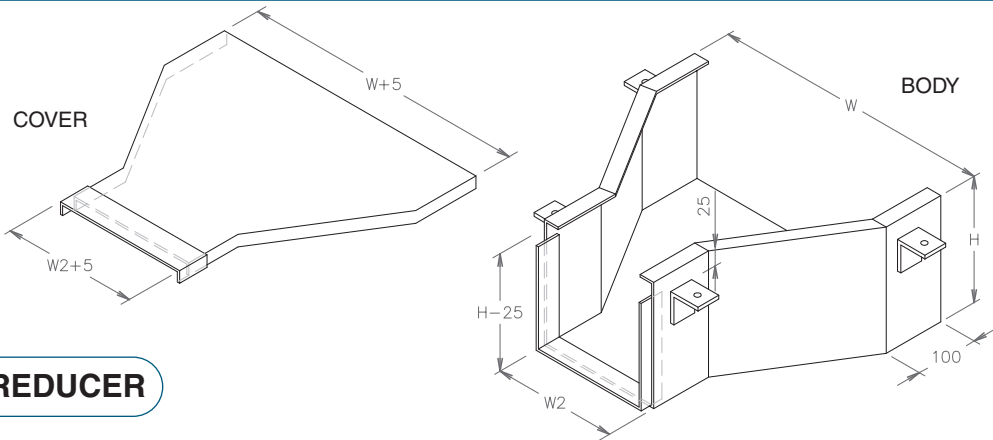

STRAIGHT REDUCER

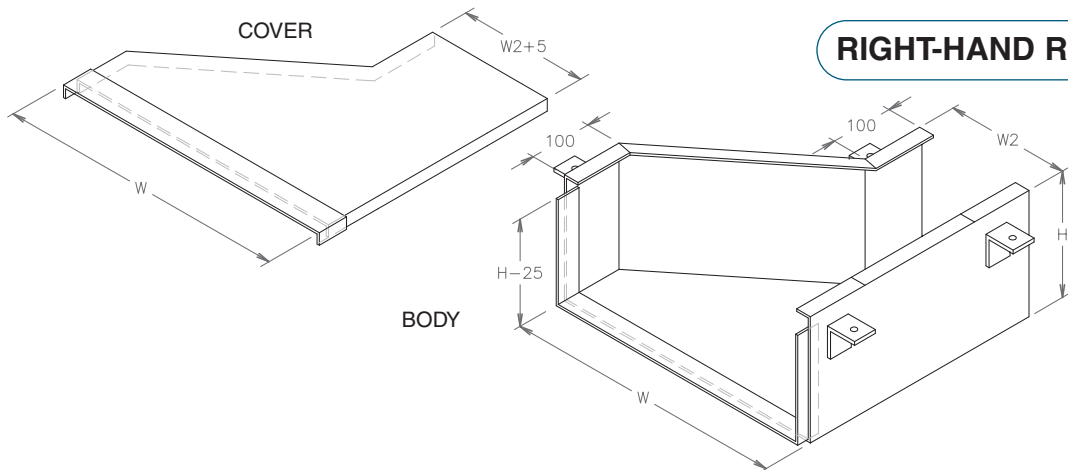

RIGHT-HAND REDUCER

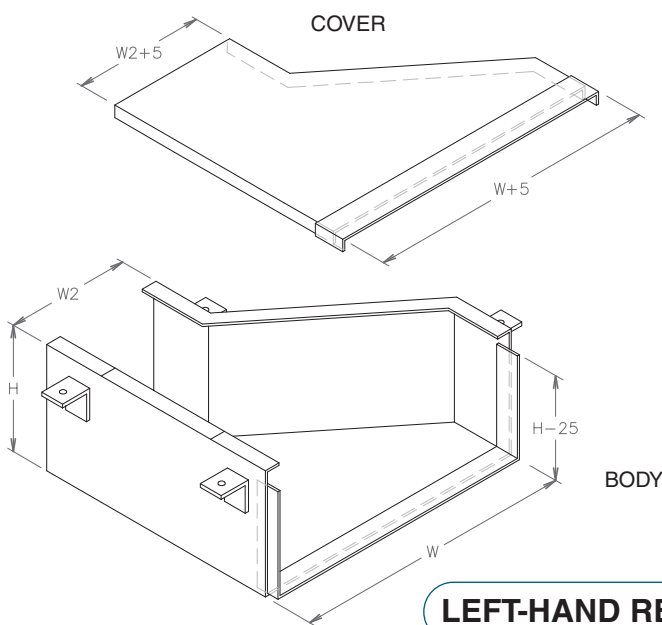

LEFT-HAND REDUCER

PRODUCT LIST

WIDTH (W)	HEIGHT (H)	WIDTH 2 (W2)	THICKNESS (T)
400	100	150	2.0
400	100	200	2.0
600	100	200	2.0
600	100	400	2.0
800	200	300	3.0
800	200	600	3.0
900	200	300	3.0
900	200	500	3.0
1000	200	300	3.0
1000	200	600	3.0
1000	300	800	3.0
1200	300	300	3.0
1200	300	600	3.0
1200	300	900	3.0

*All units in mm

NOTE: Other sizes are available upon request